

TECHNICAL FEATURES



Description

The SL16 model is a compact product and protects the traffic light during the transportation. Usable with Dual (Countdown version no) and MPB control unit.

OPTICAL FEATURES

Light source	LED	
Optics	Single sided	
Colour	Green - Amber - Red	
Lamps diameter	2x200 mm 1x300 mm	3xBasic 211 1xCountdown
Optic lifetime	> 50,000 hours	

ELECTRICAL FEATURES

Power supply	12 Vdc (11 ÷ 15 Vdc)	
Power consumption	3 W	5.5 W
Insulation class	Class III	

MECHANICAL FEATURES

Operating temperature	-10°C ÷ +55°C	
LED lamps IP protection Degree	IP55	IP65
Cart IP protection Degree	IP54	
Weight	25 Kg (without battery)	
Dimensions (Open)	787 x 455 x 2200 mm	780 x 455 x 2210 mm
Dimensions (Closed)	885 x 440 x 980 mm	940 x 440 x 730 mm
Adjustable height	1950/2075/2200 mm	1960/2085/2210 mm
LED lamps materials	Polycarbonate (Lens and body)	Polycarbonate (Lens); PA6 (Body)
Cart material	Painted galvanized steel	



Rev. 3.0

29/09/2023

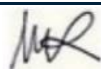

Approved TEC



Approved AQ

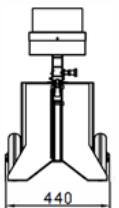
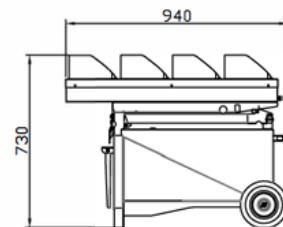
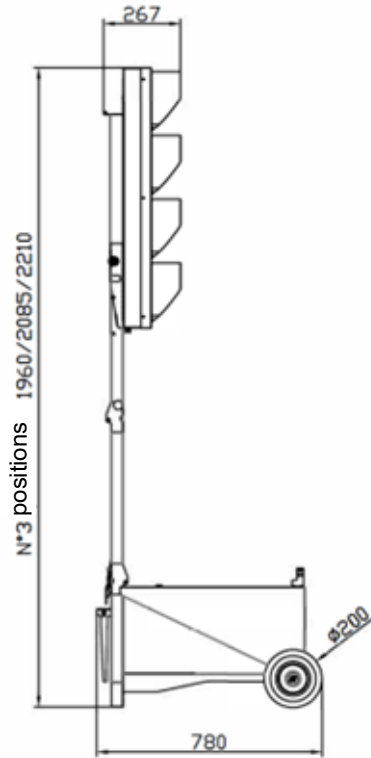
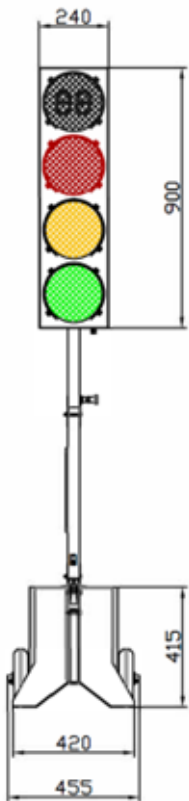
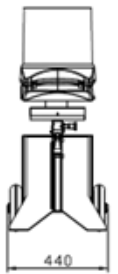
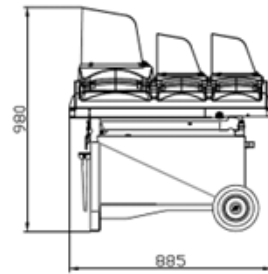
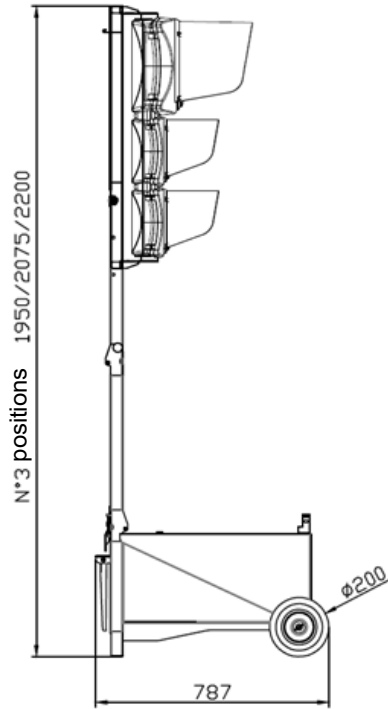
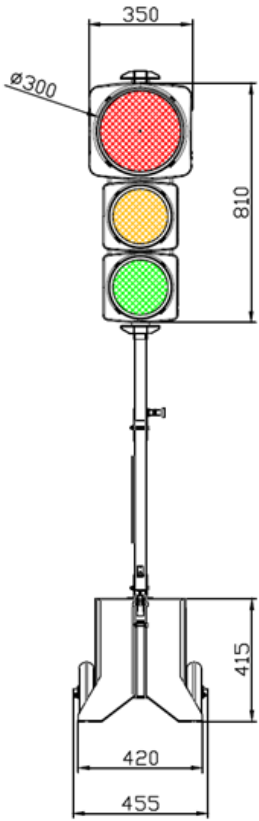

Rev. 3.0
29/09/2023

Approved TEC

Approved AQ