

SL16 Manual

TECHNICAL FEATURES



Description

It is ideal for the situations where vehicle traffic management must be manually adjusted. Equipped with a wireless remote control to activate manually green or red light.

OPTICAL FEATURES

| | |
|----------------|--|
| Light source | LED |
| Optics | Single sided (3xBasic211); 360° (400 LED series) |
| Colour | Green - Amber - Red (3xBasic211); Amber (400 LED series) |
| Lamps diameter | 3 x Basic 211 + 400 LED series |
| Optic lifetime | > 50,000 hours |

ELECTRICAL FEATURES

| | |
|---------------------|---|
| Power supply | 12 Vdc (11 ÷ 15 Vdc) |
| Power consumption | 3 W (3xBasic211); 10.8 W (400 LED series) |
| Range in free space | 40 m |
| Insulation class | Class III |

MECHANICAL FEATURES

| | |
|-------------------------------------|----------------------------------|
| Operating temperature | -10°C ÷ +55°C |
| 400 LED series IP protection Degree | IP65 |
| LED lamps IP protection Degree | IP65 |
| Cart IP protection Degree | IP54 |
| Weight | 25 Kg (without battery) |
| Dimensions (Open) | 787 x 440 x 2215 mm |
| Dimensions (Closed) | 980 x 440 x 640 mm |
| Adjustable height | 1965/2090/2215 mm |
| 400 LED series materials | Polycarbonate (Lens); ABS (Base) |
| LED lamps materials | Polycarbonate (Lens); PA6 (Body) |
| Cart material | Painted galvanized steel |



Rev. 3.0

29/09/2023

Approved TEC

Approved AQ

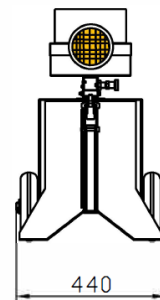
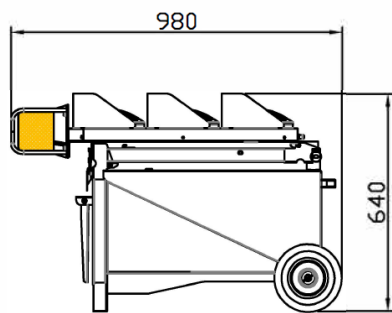
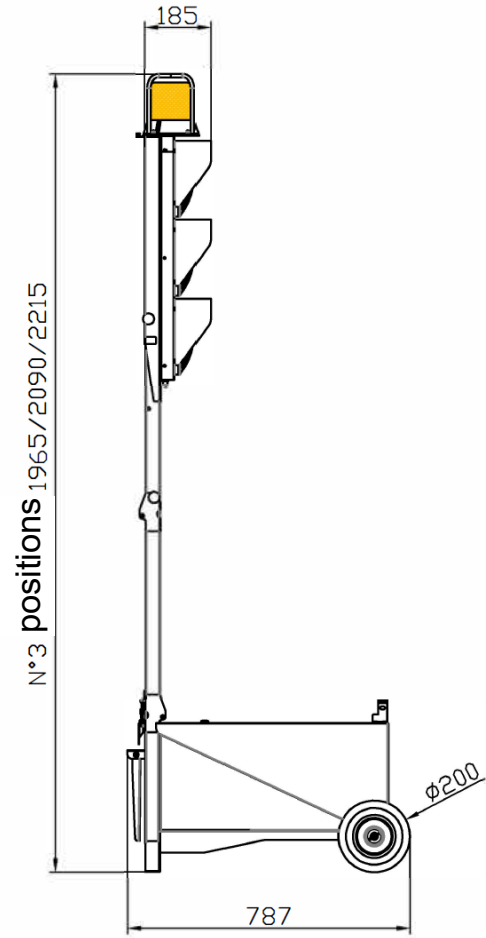
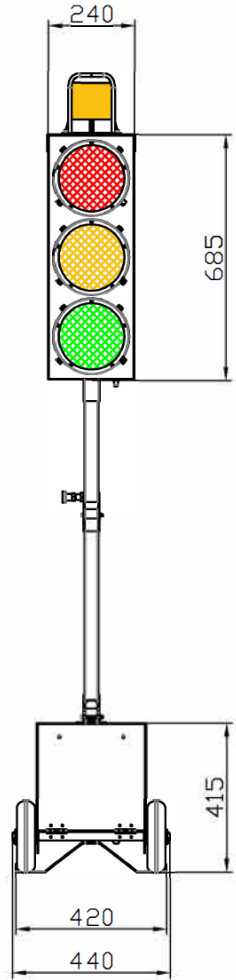

Rev. 3.0
29/09/2023

Approved TEC

Approved AQ